

EBS
Ink-Jet Systeme

Brought to you by
R.V.Entreprises, Thane.
Ph. 022-25472494

HANDJET
EBS-250

HANDJET EBS-250

The HANDJET EBS 250 is an innovative product made by EBS Ink-Jet Systeme GmbH.

Based on the established production line Ink-Jet printer PicAS EBS-200 combined with intensive research we developed a fully versatile and wireless handcoder marking the beginning of a new era in inkjet-coding.

The ultra-light and compact design of the HANDJET EBS-250 (weight of < 1000g incl. battery and ink cartridge) simplifies marking, coding and signing.

The HANDJET EBS-250 with its patented print technology replaces traditional hand coders (such as stencil machines, stamps and roll coders which are laborious and expensive in use and problematic with ink management).

Our new inkjet coder allows for fast and clean printing on various surfaces such as metal, glass, plastic and, of course, cardboard using many solvent based inks in different colours.

By efficient use of energy the HANDJET EBS-250 can print up to 50 hours non-stop and the Li-Ion rechargeable battery needs less than 2.5 hours for recharging.

The easy to use Microsoft™ Windows®-based user interface programme transmits messages that have been created within seconds to the handcoder. Also pre-defined logos from Windows® fonts and symbols as well as diacritical characters can be easily transferred. Included are special registers like date, time, up- and down counters.

Up to 1500 characters can be efficiently stored in the handcoder's memory including up to 10 message blocks with several lines in each block.

The ink cartridge has an extremely long lifetime (up to 100 000 characters with dot matrix 7x5). This guarantees for an efficient use of consumables.

The required messages are transferred by a RFI-radio frequency Interface (USB) speedily to the HANDJET EBS-250 within a range of 50 metres. One PC can easily control several HANDJETs with one RFI.

**HANDJET EBS-250:
Ink-Jet technology
for the future!**

PIF Gold Medal Winner



For the best products incorporating the latest technological solutions and of top quality. TAROPAK 2005, Poznan.

Microsoft™ and Windows® are registered trademarks of Microsoft™ Cooperation USA and other countries.

Brought to you by
R.V.Entreprises, Thane.
Ph. 022-25472494



Technical Parameters

Number of nozzles	16	Timing	either synchronised with rotational speed of the lower stabilisor or at intervals by an internal generator
Nozzle diameter	150 µm	Power supply	Battery powered by 3 Li-Ion cells
Print height	11 mm, 20 mm and 27 mm	Approximate operating time with the battery fully charged	50 hours - of non-stop printing at a temperature of 20°C, automatic low-battery indication.
Height of objects to be printed	from 35 mm	Recharging	automatically via an external 24V/1A DC power pack. Charging time, less than 150 minutes
Working position in 3D space	any	Ink	available in easily removable cartridges, ethanol-, acetone- or water based, in various colours
Line printing	enables printing of up to 10 texts in successive lines	Cartridge capacity	110 ml for printing about 100.000 characters with 7x5 dot matrix or about 17.000 characters with 16x10 dot matrix
max. number of characters per text	1500 (including control characters for the printer's built-in fonts)	Working pressure	0,3 bar to 0,4 bar
Number of texts and accompanying print param.	from 1 to 10 (Texts are loaded into the printer via PC)	Operating temp. range	+0,5°C to +40°C
Printing of graphics (logo, special graphic characters)	editing and printing of graphical texts and symbols with the use of Windows®-Fonts (True Type) as standard	Storage temperature range	- +1°C to +45°C with water based ink - -10°C to +45°C with acetone or ethanol based ink
Special characters	national (diacritical) characters, graphic characters for information, warnings, etc.	Humidity	Up to 95% without steam condensation (the printer can be operated when it rains, on a dry surface)
Variable fields	date and time in any format, expiry date, up- and down counters, universal counter (pieces, pallets, metres, etc.)		
Programming	- wireless (radio) with range of up to 50 m - Text- and parameter processing Software, Windows® 98SE/ME/NT/2000/XP - Network of up to 20 printers, radiocontrolled via PC		

EBS GmbH reserves the right to change these specifications without prior notice.

Dimensions: side and front views

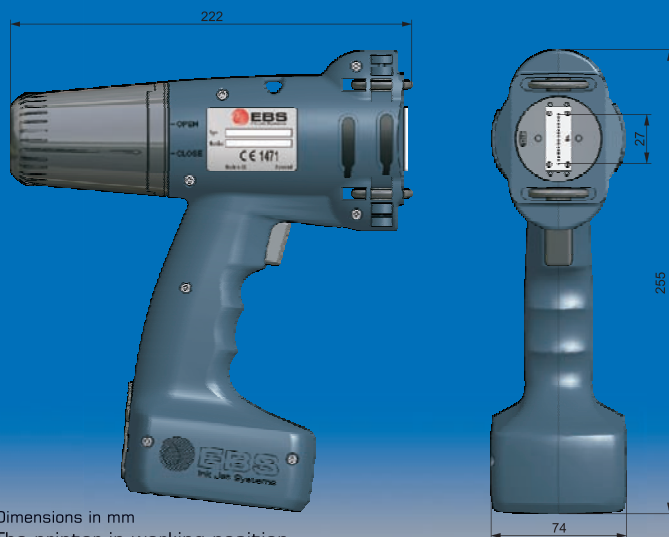

Dimensions in mm
The printer in working position

Patents:
WO 99/48694; EP 1219439; EP 12194323

Protection of designs



Manufacturer:
EBS Ink-Jet Systeme GmbH
Alte Ziegelei 19-25
D-51588 Nümbrecht-Elsenroth
Tel: +49 (0) 22 93/93 9-0
Fax: +49 (0) 22 93/93 9-3
www.ebs-inkjet.de

Accessories

Standard:

- Case to hold all accessories
- HANDJET EBS-250 Printer
- Spray bottle
- Power pack 24V/1A with cable
- CD with utility software and user-support files
- RFI-Module for wireless data transfer (USB)
- Cable for RFI-Module to PC (USB)

optional:

- Stabilisor wheels for exact printing on curved surfaces

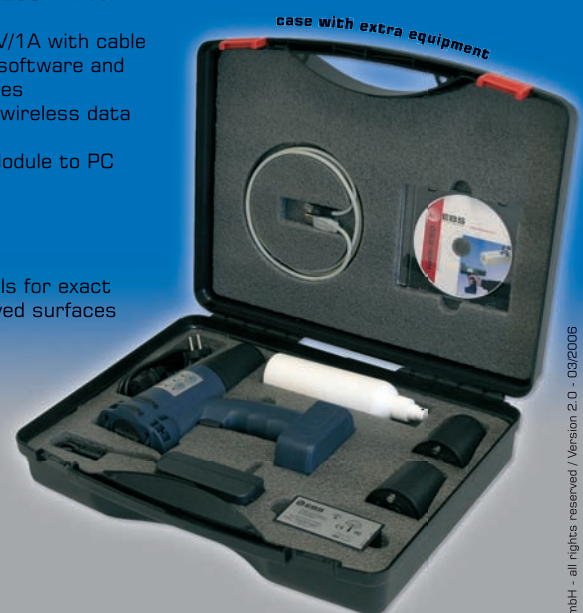

Distributor:

R.V.Enterprises.
1, Sonal Apt., Uthalsar Road,
Thane (W) - 400601,
Maharashtra, India.
Ph. 022-25472494 / 9323568697.
email - rventerprises83@gmail.com